

Montagem referente a motor WEG IP-21

SUCÇÃO: 1" BSP

RECALQUE: 1" BSP



Tabela de Medidas

Modelo	CV	L	B	F1	F2	HD						
P-11/2 Monof.	1/2	395	---	160	100	198						
P-11/2 Trif.		388				---						
P-11/2 Monof.	3/4	408				---						
P-11/2 Trif.		398				---						
P-11/2 Monof.	1,0	408				127	190	130	210			
P-11/2 Trif.		---							---			
P-11/2 Monof.	1,5	438	127	190	130				210			
P-11/2 Trif.		428							---			
P-11/3 Monof.	1,0	438							127	220	160	210
P-11/3 Trif.		---										---
P-11/3 Monof.	1,5	468				127	220	160				210
P-11/3 Trif.		458										---
P-11/3 Monof.	2,0	488	127	220	160							210
P-11/3 Trif.		468										---
P-11/4 Monof.	1,5	498							127	220	160	210
P-11/4 Trif.		488										---
P-11/4 Monof.	2,0	518				127	220	160				210
P-11/4 Trif.		498										---
P-11/4 Monof.	3,0	538	127	220	160							210
P-11/4 Trif.		518										---

	EXECUTADO	A.P.Scarpel	16/05/03					
	VERIFICADO	A.P.Scarpel	16/05/03					
	APROVADO	A.P.Scarpel	16/05/03					
	NOME	DATA CRIAÇÃO	OBSERVAÇÃO	REVISÃO	LOCAL	Nº DOCUM.	DATA	APROVADO
				00	---	---	16/05/03	Garcia

Bomba P-11/2-4 Jet Pump

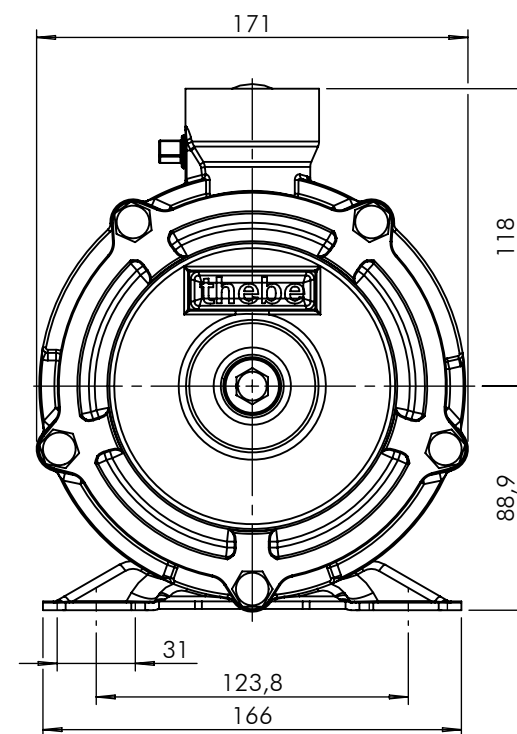
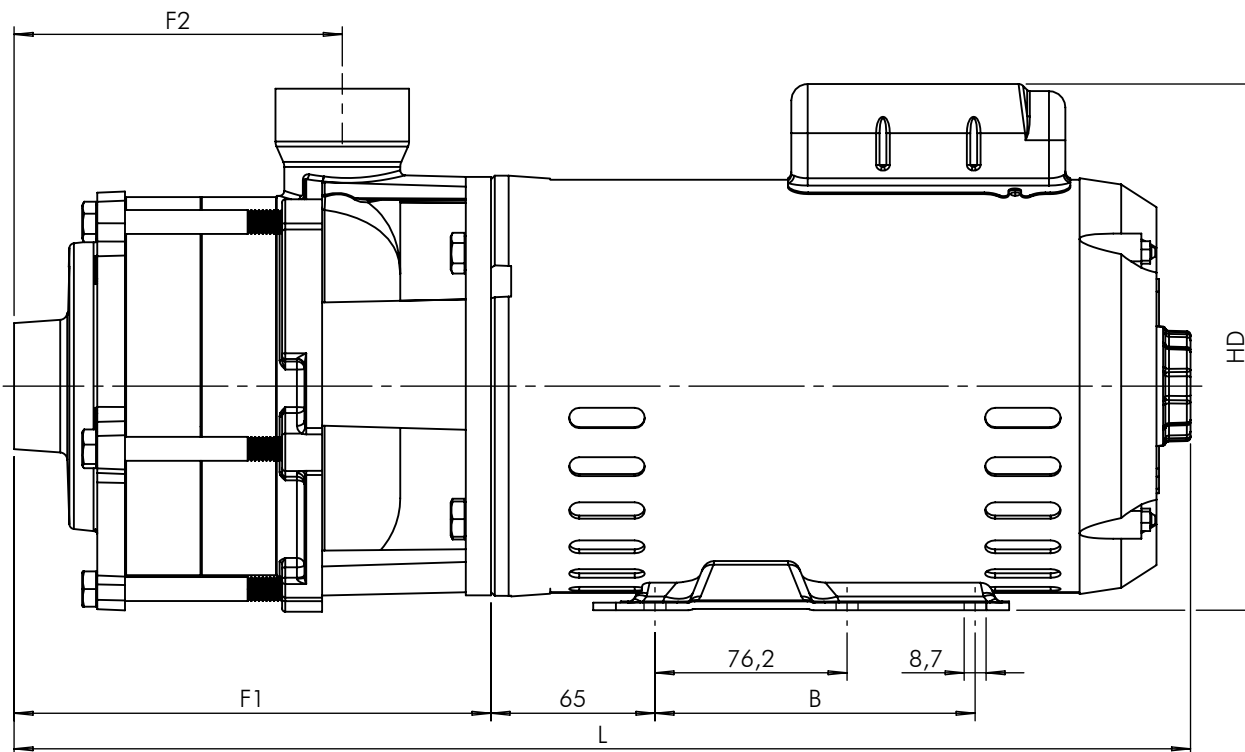
DESENHO Nº 071112 ESCALA: 1:3